

STOCKHOLM 1100

Vinyl Furniture

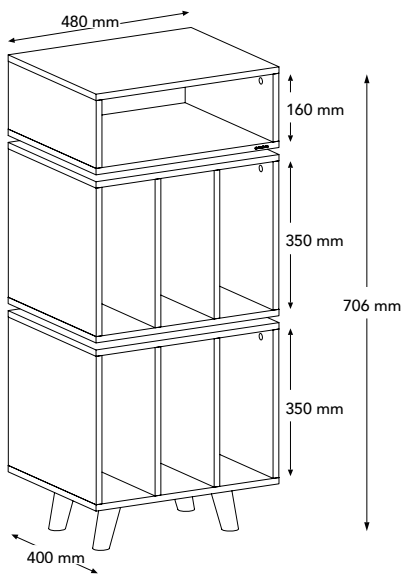

DIMENSIONS



DESCRIPTION

The Stockholm 1100 takes the DNA of the Stockholm 700 and adds a second level of storage for vinyl records.

It offers two dedicated tiers with three vertical compartments, making it easy to organise your collection. As with the 700 version, the upper section accommodates electronics with a height of 160 mm and a width of 480 mm, a format suitable for most amplifiers and pre-amplifiers on the market. The top shelf provides space for a turntable, transforming the unit into a true all-in-one solution that can hold vinyl records, electronics and a turntable in a space-saving design.

The Stockholm 1100 is available in two finishes: white and light oak or black and walnut.

QUANTITY OF VINYL & MAX WEIGHT

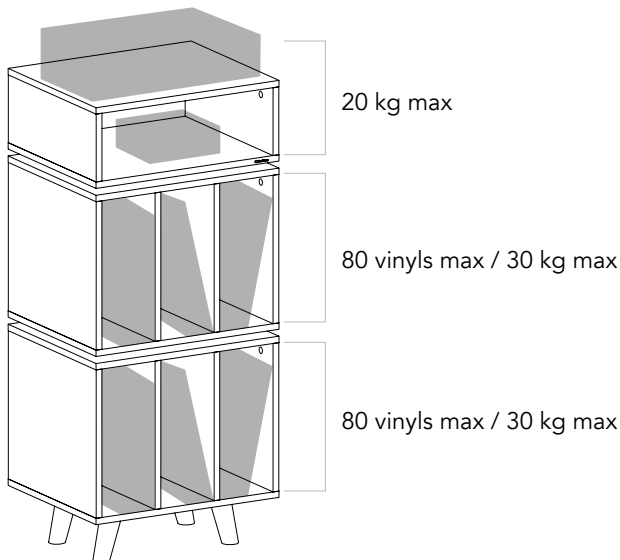



DESIGN

Structure : Melamine
Finishes: *Black satin / Walnut*
White / Clear oak

MAX LOAD

20 kg for the electronic unit
30 kg for each vinyl cabinet

USEFUL DIMENSIONS

External dimensions (L x H x P) :
480 x 1103 x 400 mm

PACKAGING

Delivered unassembled, plan required for assembly

Quantity / box : 1

Type : *Brown box*

Dimensions (L x H x P) : 575 x 300 x 500

Gross weight : 32,1 kg

Net weight : 29,8 kg

PRODUCT CODES

 **FINISH** : Black satin / Walnut
EAN : 3700795181690
SKU : NORSTO110ABSWN

 **FINISH** : White / Clear oak
EAN : 3700795181706
SKU : NORSTO110AWTOK

IN THE SAME RANGE



STOCKHOLM 700